



**SHUR-LOK CORPORATION**  
**TECHNICAL SALES BULLETIN**

**TSB**

**0008**

**TITLE:**           **INSTALLATION PROCEDURE FOR**  
**SL850 AND SL854 PULL-UP TYPE INSERTS**

Rev: NC                   Date:  
                                  01OCT00

Page 1 of 11

**1.0 INTRODUCTION:**

- 1.1 This Technical Sales Bulletin describes installation procedure of SL850 Blind-Threaded and SL854 Thru-Threaded Pull-up type inserts. These procedures use the SLPGA850 Power tool and SLT850S300 hand tool.
- 1.2 These two types of inserts are designed to be used on aluminum or mild steel structure, solid aluminum or mild steel sheet/plate and some aluminum or mild steel tubing. Below are examples of each series and styles available:

**SL850**  
**Blind-Threaded**



**SL854**  
**Thru-Threaded**



**2.0 INSERT SELECTION:**

When selecting a pull-up insert please refer to the latest revision of SL850 and SL854 sales drawings. Attention needs to be given to:

- Type-                   Blind or Thru- Threaded
- Material-               Alloy Steel or Stainless Steel
- Thread size-           Inch or Metric
- Head Style-            Flush or Flat, Self-Locking or Non-Locking
- Sheet Thickness-      It is very important the insert matches the appropriate sheet thickness
- Finish-                Required finish must be specified





**SHUR-LOK CORPORATION**  
**TECHNICAL SALES BULLETIN**

**TSB**

**0008**

**TITLE:**           **INSTALLATION PROCEDURE FOR**  
**SL850 AND SL854 PULL-UP TYPE INSERTS**

Rev: NC

Date:  
01OCT00

Page 3 of 11

**4.0    SLPGA850 POWER TOOL INSTALLATION:**

This section describes installation procedure of SL850 Blind-Threaded and SL854 Thru-Threaded Pull-up type inserts using the SLPGA850 Power tool.

**Note:** This TSB is to used in conjunction with the latest revision of Shur-Lok's SLD850 data sheets.

**5.0    SLPGA850 POWER TOOL SETUP:**

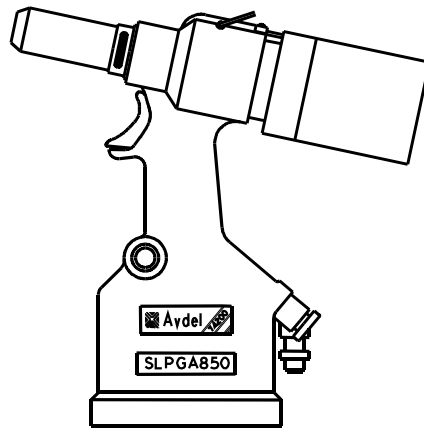

**POWER TOOL  
AS SUPPLIED**

- 5.1    Power tool kits includes:
- 1- Power tool
  - 2- Nose Guide Locknut (1 spare)
  - 1- Set of Three Open-Ended Wrenches
  - 1- Set of Three Allen Wrenches
  - 1- Manufacturers operating instructions

Nose guides and mandrels must be order separately. Please see sheet 2 of SLD850 data sheets, table I for proper nose guide and mandrel for your insert thread size.

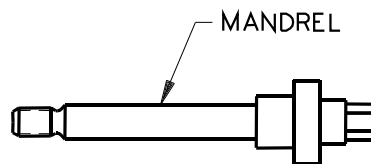
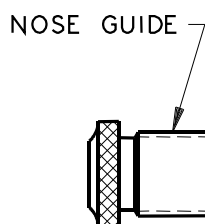



**SHUR-LOK CORPORATION**  
**TECHNICAL SALES BULLETIN**

**TSB**

**0008**

**TITLE:**       **INSTALLATION PROCEDURE FOR**  
**SL850 AND SL854 PULL-UP TYPE INSERTS**

Rev: NC

Date:  
01OCT00

Page 4 of 11

- 5.2
- a) Unthread and remove power tool nose casing to expose spindle and adapter nut.
  - b) Using open-ended wrenches supplied with power tool remove adapter nut for spindle.
  - c) Insert mandrel into spindle then replace adapter nut onto spindle. Tighten with open-ended wrenches and replace power tool nose casing.

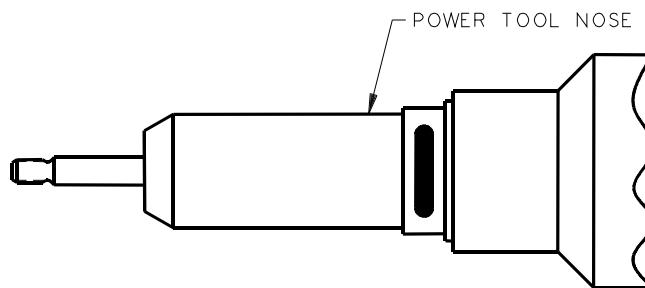

- d) Thread one (1) nose guide locknut onto nose guide until the locknut bottoms-out.

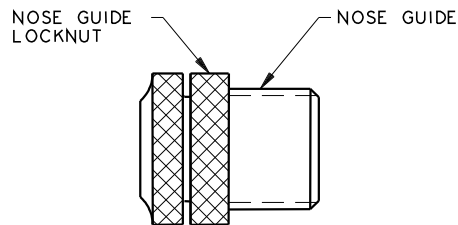

- e) Thread nose guide into power tool nose casing. Thread until nose guide locknut bottoms-out to power tool nose casing.

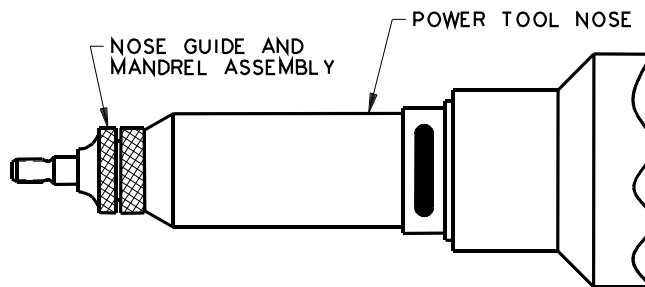

**POWER GUN NOSE ASSEMBLY**



**SHUR-LOK CORPORATION**  
**TECHNICAL SALES BULLETIN**

**TSB**

**0008**

**TITLE:** INSTALLATION PROCEDURE FOR  
SL850 AND SL854 PULL-UP TYPE INSERTS

Rev: NC

Date:  
01OCT00

Page 5 of 11

**6.0 INSERT INSTALLATION:**

6.1 Connect power tool to source compressed air.

**Note:** For proper power tool operation, consult manufacturers operating instructions supplied with kit.

- a) The stroke of power tool must be adjusted. This is accomplished by turning the rear casing (black rubber portion of power tool). To do this turn the casing "IN" (clockwise) until there is very little stroke (movement) of the mandrel when actuated.

**Note:** It is recommended to perform these adjustments on a sample plate of the same thickness before installing into working structure.

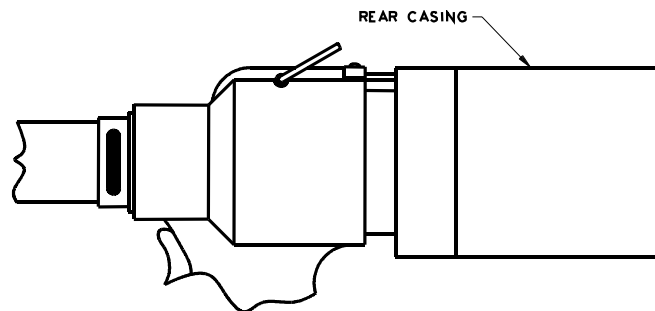

- b) Hold insert to threaded portion of mandrel.  
c) Insert threaded portion of mandrel into the threaded portion of insert.  
d) While holding insert, push into mandrel.

**Note:** Do not pull trigger of power tool, it will automatically thread mandrel to insert.

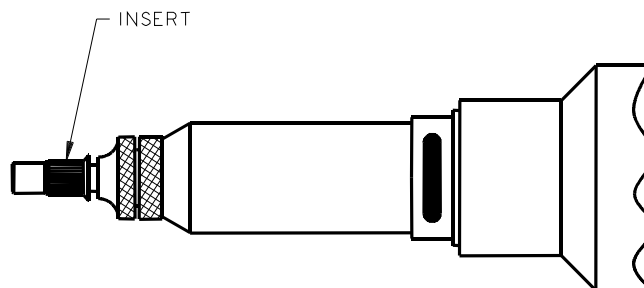



**SHUR-LOK CORPORATION**  
**TECHNICAL SALES BULLETIN**

**TSB**

**0008**

**TITLE:**       **INSTALLATION PROCEDURE FOR**  
**SL850 AND SL854 PULL-UP TYPE INSERTS**

Rev: NC

Date:  
01OCT00

Page 6 of 11

- 6.2 Thread nose guide until face contacts insert. Tighten nose guide locknut against nose casing.

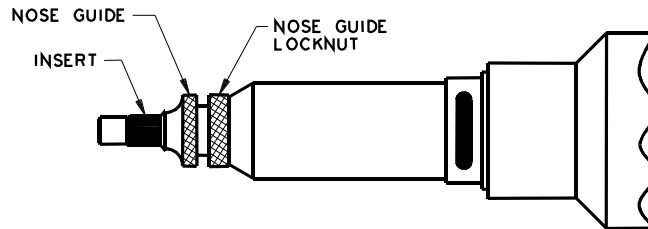

- 6.3 Place insert into prepared installation hole. Be sure to hold the face of nose guide flush to sheet structure.

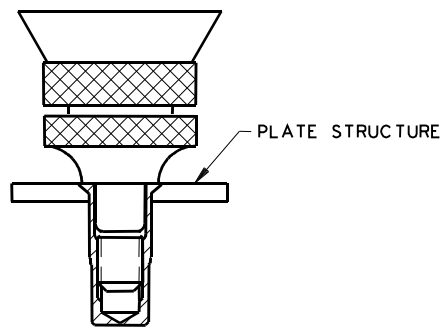

- 6.4 Maintain positive pressure and actuate power tool by pulling trigger. Do not release trigger until power tool disengages itself from insert.

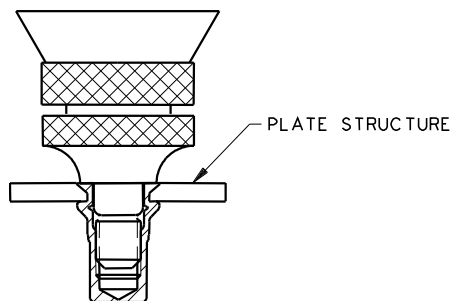





**SHUR-LOK CORPORATION**  
**TECHNICAL SALES BULLETIN**

**TSB**

**0008**

**TITLE:**           **INSTALLATION PROCEDURE FOR**  
**SL850 AND SL854 PULL-UP TYPE INSERTS**

Rev: NC                           Date:  
  01OCT00

Page 8 of 11

**7.0    SLT850S300 HAND TOOL INSTALLATION:**

This section will describe installation procedure of SL850 Blind-Threaded and SL854 Thru-Threaded Pull-up type inserts using the SLT850S300 hand tool.

**Note:** This TSB is to used in conjunction with the latest revision of Shur-Lok's SLD850 data sheets.

**8.0    SLT850S300 HAND TOOL SETUP:**

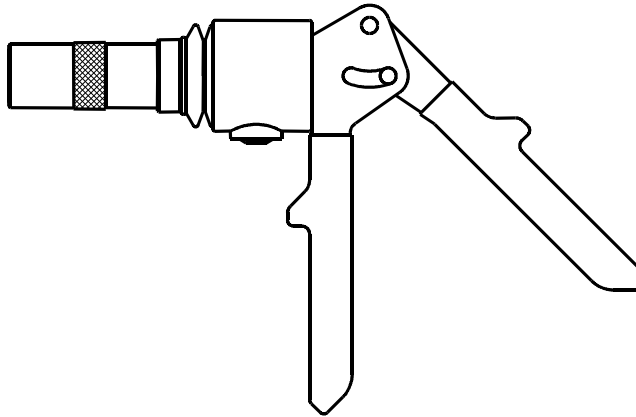

**HAND TOOL  
AS SUPPLIED**

- 8.1    Hand tool kit includes:
- 1- Hand tool
  - 1- Hand tool nose guide (Part number: SLT850S300-2)
  - 1- Plastic case
  - 1- Operating instructions

Bushings and mandrels must be order separately. Please see sheet 3 of SLD850 data sheets, table I for proper nose guide and mandrel for your insert thread size.

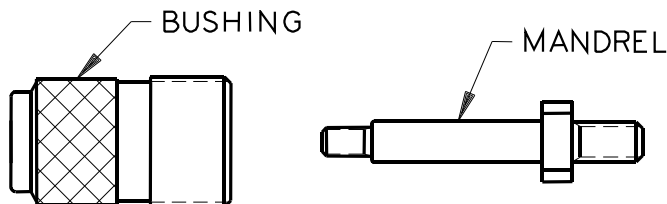



**SHUR-LOK CORPORATION**  
**TECHNICAL SALES BULLETIN**

**TSB**

**0008**

**TITLE:** INSTALLATION PROCEDURE FOR  
SL850 AND SL854 PULL-UP TYPE INSERTS

Rev: NC

Date:  
01OCT00

Page 9 of 11

- 8.2 a) Thread and tighten mandrel into hand tool guide.

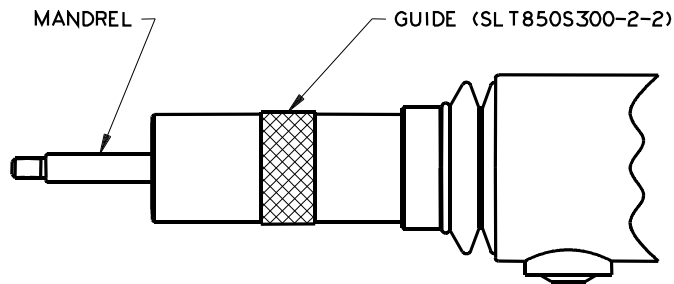

- b) Thread bushing into hand tool guide. Thread until bushing bottoms-out in hand tool guide.

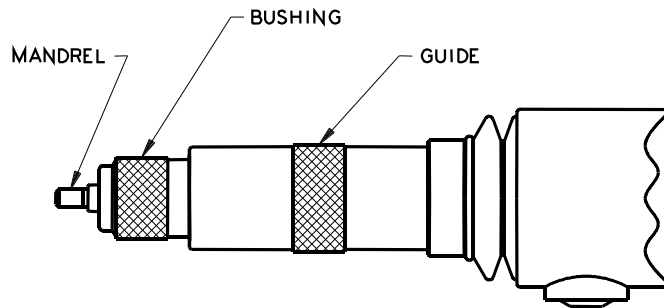

**9.0 INSERT INSTALLATION:**

- 9.1 Thread insert as far as possible onto threaded portion of mandrel.  
9.2 Thread bushing counterclockwise until the face of bushing contacts insert.

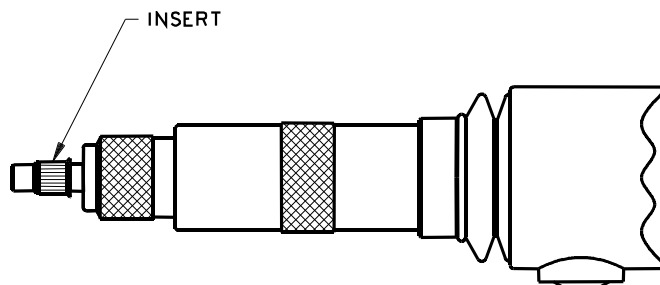



**SHUR-LOK CORPORATION**  
**TECHNICAL SALES BULLETIN**

**TSB**

**0008**

**TITLE:**       **INSTALLATION PROCEDURE FOR**  
**SL850 AND SL854 PULL-UP TYPE INSERTS**

Rev: NC

Date:  
01OCT00

Page 10 of 11

- 9.3 Place insert into prepared installation hole. Be sure to hold bushing face flush to sheet structure.

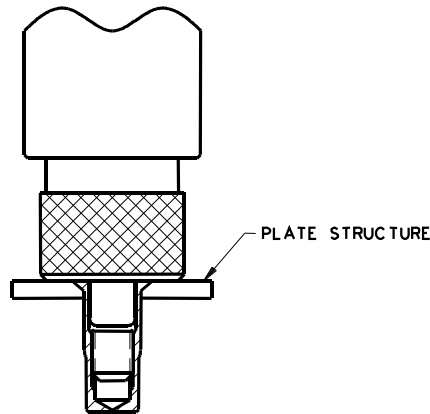

- 9.4 Maintain positive pressure and actuate tool by squeezing the handles on the hand tool together. Use short strokes to control the speed of the collapsing insert.
- 9.5 Collapse insert until an even “Deformation” is produced around the structure. Using a 5x-magnification eyeglass, look for an even radius under “Deformation” next to insert shank. If “Deformation” is insufficient, the insert will rotate in installation hole. Care must be taken not to over collapse. If “Deformation” collapses in on itself, it has been pulled-up too far and will cause insert threads to distort; insert fracture or mandrel can break.

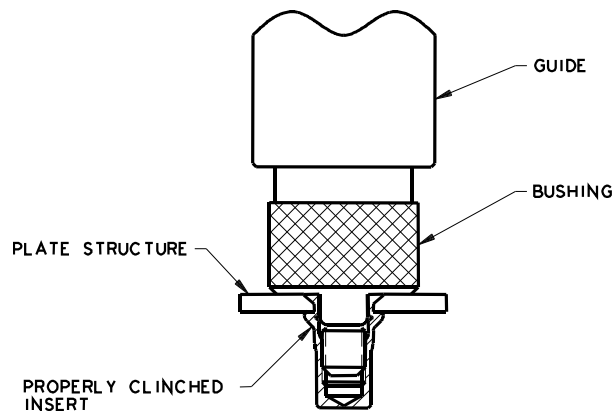



**SHUR-LOK CORPORATION**  
**TECHNICAL SALES BULLETIN**

**TSB**

**0008**

**TITLE:**        **INSTALLATION PROCEDURE FOR**  
                  **SL850 AND SL854 PULL-UP TYPE INSERTS**

Rev: NC

Date:  
01OCT00

Page 11 of 11

- 9.6 To disengage hand tool from installed insert, hold the handles of hand tool together on the last stroke (or squeeze) then press pressure release button located under the guide on the base portion of hand tool.

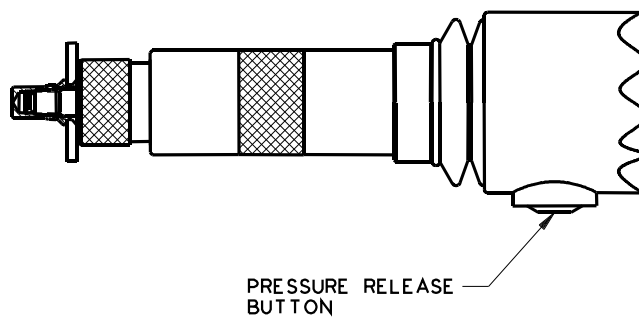

- 9.7 After pressure is released unthread mandrel from installed insert.

