



SHUR-LOK CORPORATION
TECHNICAL SALES BULLETIN

TSB 0010

REV: NC

DATE: 8-7-98

TITLE: SL7620 Key-Fast Locknut Assembly and Shaft Key-Way Preparation

Note: Use this TSB in conjunction with latest revision of Shur-Lok Sales Drawing number SL7620.

General Description of System:

1.0 SL7620 Key-Fast Locknut

1.1 Shur-Lok Corporation developed the SL7620 Key-Fast Locknut to cover the needs of a wide range of applications requiring a quick, self-contained, no special tools, compact, re-usable, positive locking method for threaded components.

1.2 The SL7620 Locknut consists of three components; a locknut, a mating lockwasher and a lockring. These components are then assembled on a threaded shaft with two keyways per paragraph 2.0. See exploded view of components below.

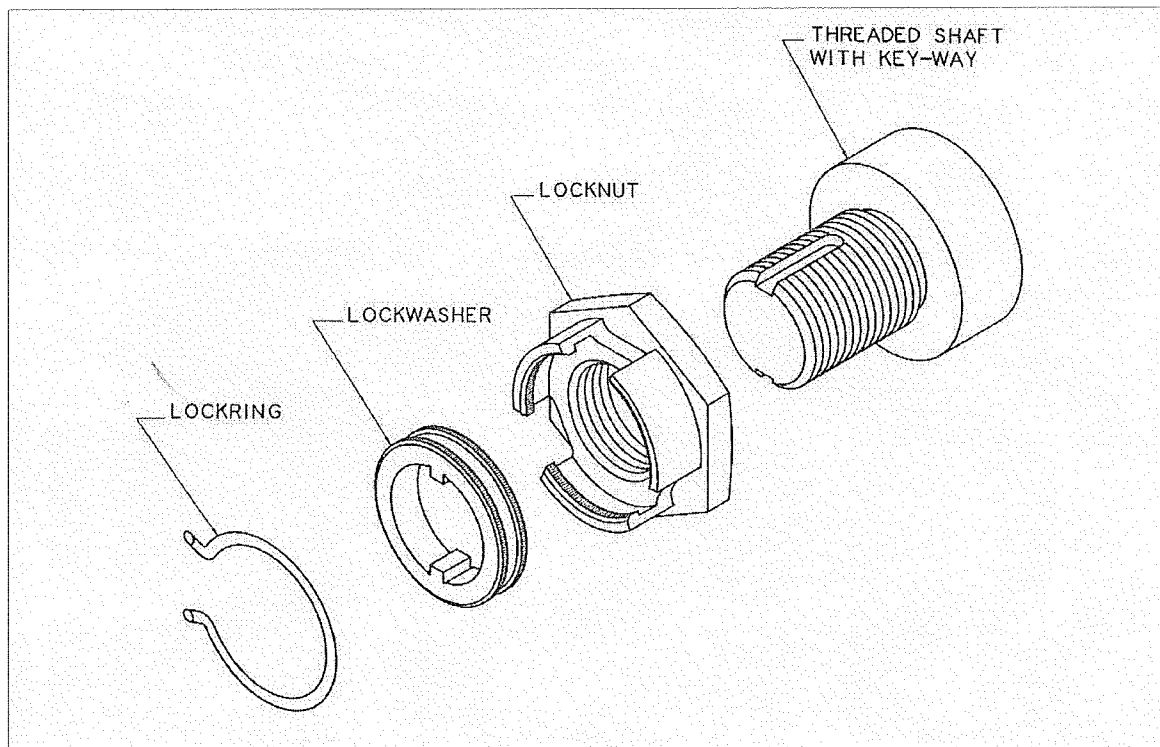



SHUR-LOK CORPORATION
TECHNICAL SALES BULLETIN

TSB 0010

REV: NC

DATE: 8-7-98

TITLE: SL7620 Key-Fast Locknut Assembly and Shaft Key-Way Preparation

2.0 SL7620 Shaft Key-Way Preparation.

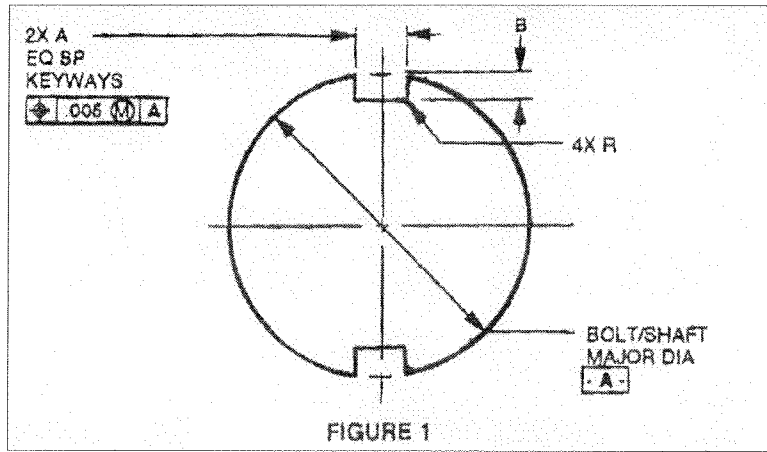

2.1 Prepare key-ways using dimensions noted in table 1 and corresponding detail of Figure1.

Table 1:

Size	Thread (Ref)	A +.005 -.000	B ±.005	R RAD
4	.2500-28	.073	.065	.003-.010
6	.3750-24	.094	.070	.003-.010
8	.5000-20	.125	.075	.003-.010



SHUR-LOK CORPORATION
TECHNICAL SALES BULLETIN

TSB 0010

REV: NC

DATE: 8-7-98

TITLE: SL7620 Key-Fast Locknut Assembly and Shaft Key-Way Preparation

TABLE 1 (contd)

Size	Thread (Ref)	A +.005 -.000	B ±.005	R RAD
10	.6250-18	.156	.083	.005-.015
12	.7500-16	.156	.088	.005-.015
14	.8750-14	.156	.093	.005-.015
16	1.0000-12	.156	.101	.005-.015
18	1.1250-12	.188	.101	.005-.015
20	1.2500-12	.188	.101	.005-.015
22	1.3750-12	.188	.101	.005-.015
24	1.5000-12	.188	.101	.005-.015
26	1.6250-12	.188	.101	.005-.015
28	1.7500-12	.188	.101	.005-.015

